

4

3

2

1

HEADS UP TECHNOLOGIES, INC. PROPRIETARY  
THE INFORMATION CONTAINED HEREIN IS PROPRIETARY TO HEADS UP TECHNOLOGIES, INC. AND SHALL NOT BE DISCLOSED IN WHOLE OR IN PART OR USED FOR ANY PURPOSE EXCEPT WHEN SUCH USER POSSESSES DIRECT WRITTEN AUTHORIZATION FROM HEADS UP TECHNOLOGIES, INC.

REVISIONS			
REV	DESCRIPTION	DATE	CHANGED BY
A	INITIAL RELEASE	2/19/09	G.SNYDER

NOTES: UNLESS OTHERWISE SPECIFIED:

- UNIT WEIGHT IS APPROX .30 LBS.
- LIGHT IS DESIGNED TO BE USED WITH PSM120-01 OR EQUIVALENT CONSTANT CURRENT POWER SUPPLY AND IS SUPPLIED WITH A MOLEX CONNECTOR(43645-300(SHELL) 43030-0008(FEMALE CRIMP TERMINAL)). DO NOT HOOK UP DIRECTLY TO AIRCRAFT POWER.
- THIS DRAWING IS AN INTERFACE CONTROL DRAWING THAT REFERENCES A HEADS UP TECHNOLOGIES P/N - RDG250-XX-YY AND ALL DIMENSIONS AND SPECIFICATIONS ARE FOR REFERENCE ONLY.  
-XX REFERS TO BEZEL STYLE( SEE SHEET 2)  
-YY REFERS TO DECORATIVE PLATING OPTION DETERMINED BY HEADS UP TECHNOLOGIES DRAWING, PS-001.
- PHOTOMETRIC CHARACTERISTICS:  
LUMENS: 180-230  
TYPICAL COLOR TEMPERATURE: 5600K
- EXCEPT WHERE NOTED (X.XXX) DIMENSIONS SHOWN ARE FOR REFERENCE ONLY.

(X.XXX) = KEY CHARACTERISTIC INSPECTION DIMENSION.

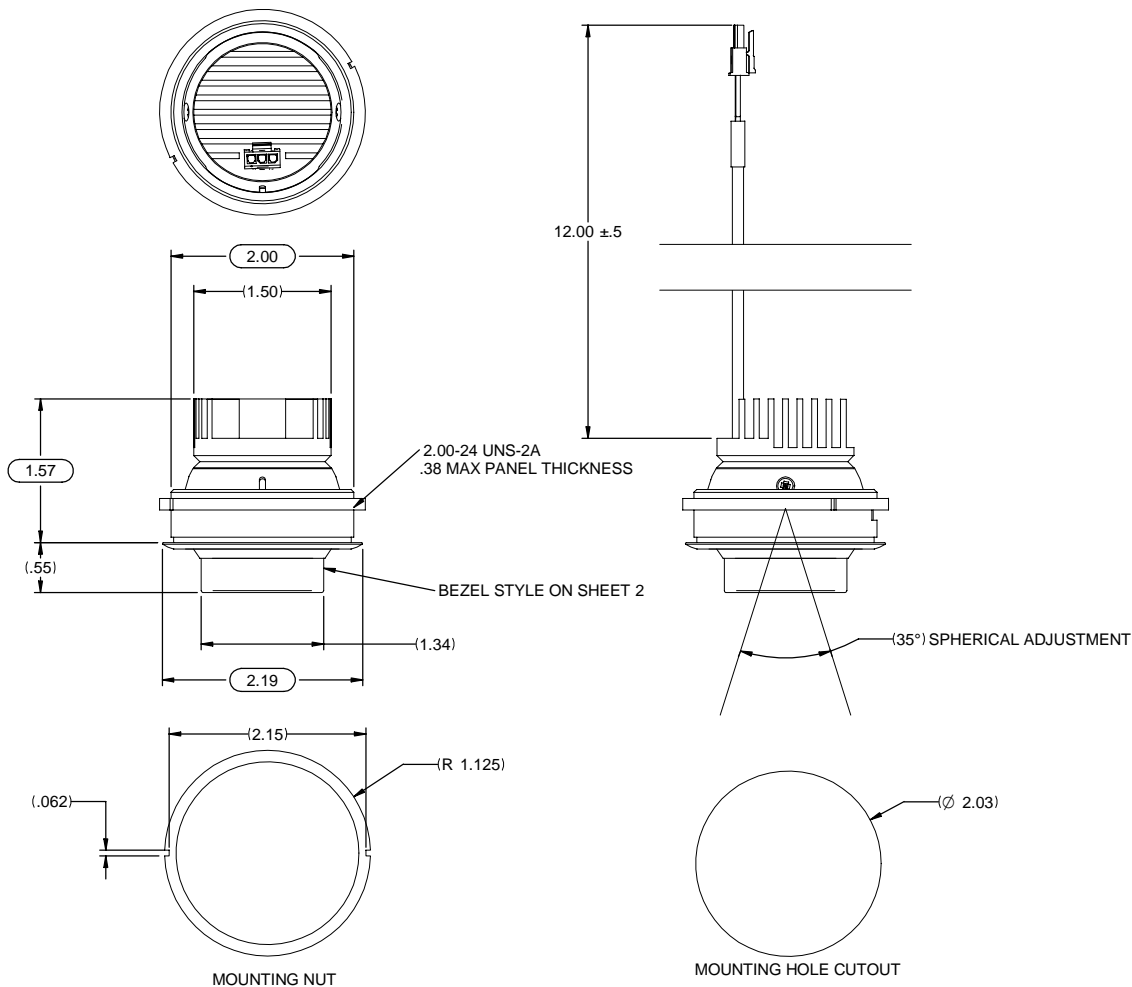
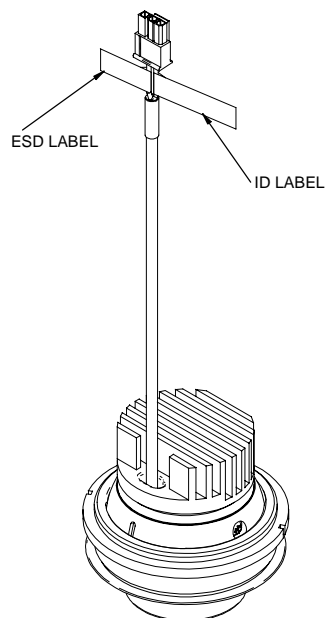

PARTS LIST			
NEXT ASSY N/A	UNLESS OTHERWISE SPECIFIED - DIMENSIONS ARE IN INCHES - (MILLIMETERS) - INTERPRET DRAWINGS PER ANSI Y14.5, 1994 - DIMENSIONS APPLY BEFORE FINISH PROCESSES - PARENTHERICAL INFO FOR REF ONLY - CONCENTRICITY MACHINED DIAMETERS - .010 TIR	DWN: G.SNYDER	DATE: 2-4-09
FINAL ASSY N/A		DRCK: D.CAPKA	DATE: 2-19-09
		ENGR: G.SNYDER	DATE: 2-4-09
		APPROV: J.NEWBY	DATE: 2-19-09
		RELEASED: C.FARRISH	DATE: 2-19-09
		CONTRACT:	
		PROJECT:	
		SCALE: 1:1	

**H** Heads Up Technologies  
2033 Glenloch Drive Suite 100  
Carrollton, TX 75006 (972) 980-4890

INTERFACE CONTROL DRAWING  
READING LIGHT

SIZE: C	DRAWING NO: RDG250-ICD	REV: A
SCALE: 1:1		SHEET 1 OF 2

4

3

2

1

4

3

2

1

HEADS UP TECHNOLOGIES, INC. PROPRIETARY  
THE INFORMATION CONTAINED HEREIN IS PROPRIETARY TO HEADS UP TECHNOLOGIES, INC. AND SHALL NOT BE DISCLOSED IN WHOLE OR IN PART OR USED FOR ANY PURPOSE EXCEPT WHEN SUCH USER POSSESSES DIRECT WRITTEN AUTHORIZATION FROM HEADS UP TECHNOLOGIES, INC.

NOTES: UNLESS OTHERWISE SPECIFIED:

D

D

C

C

B

B

A

A

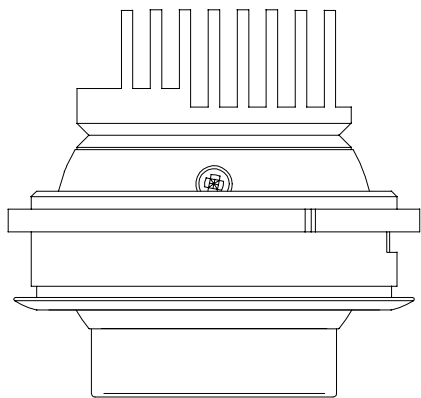

-01

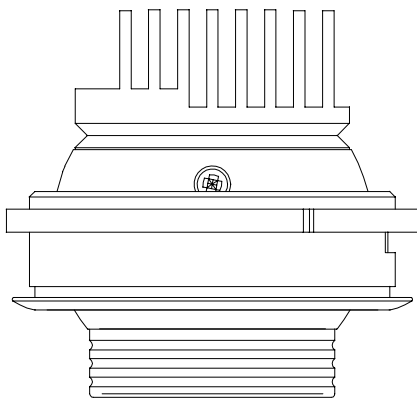

-02

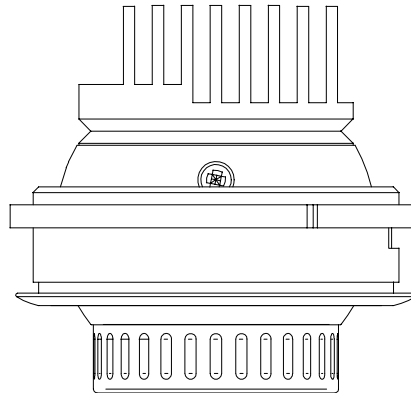

-03

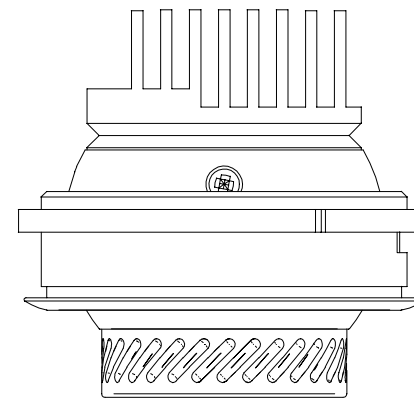

-04

BEZEL STYLES

 Heads Up Technologies	DWN	DATE	SIZE	DRWING NO.	REV
	G.SNYDER			CRDG250-ICD	A
SCALE 1:1		FILE NAME: RDG250-ICD_A.dft			SHEET 2 OF 2

4

3

2

1